

Name _____ Date _____

Class/Hour _____ Rotation # _____

Activity 1 Worksheet

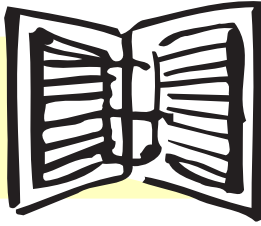

Precision Measure Student Workbook

At the end of each activity, follow the instructions for taking the daily response tests. Write down your answers on this sheet and keep it to turn it in to your instructor. Do not write inside the workbook.

Section I

Reduce the following fractions to their lowest terms. If one cannot be reduced any further, write "lowest term" on the blank.

1. $\frac{2}{8}$ _____

2. $3\frac{8}{16}$ _____

3. $5\frac{3}{16}$ _____

4. $1\frac{10}{16}$ _____

5. $2\frac{7}{8}$ _____

6. $\frac{9}{16}$ _____

7. $4\frac{4}{16}$ _____

8. $\frac{13}{16}$ _____

9. $2\frac{2}{16}$ _____

10. $6\frac{15}{16}$ _____

Section II

Using the fractional rule to measure the sides of the blocks as indicated by the diagrams below. Record the measurements by writing them on the respective lines. Be sure to record the fractions in their lowest terms.

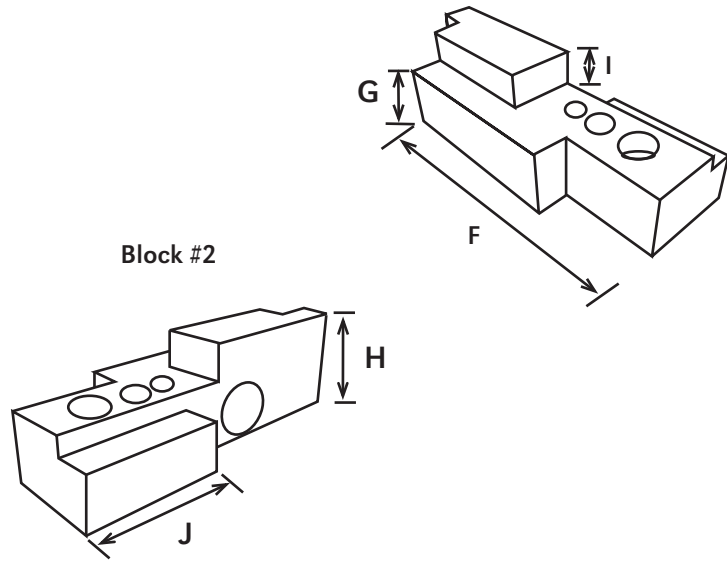
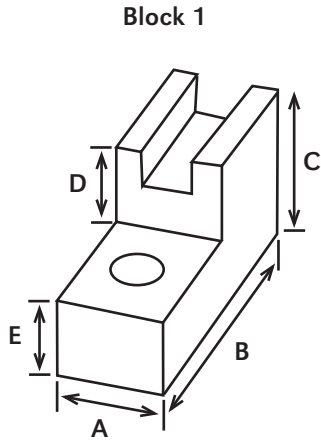

Block 1: 1/16

A. _____

B. _____

C. _____

D. _____

E. _____

Block 2: 1/32

F. _____

G. _____

H. _____

I. _____

J. _____